

LOW PROFILE HEPA-VENT

MODEL: LOW-A (20-40 CFM/FT²)

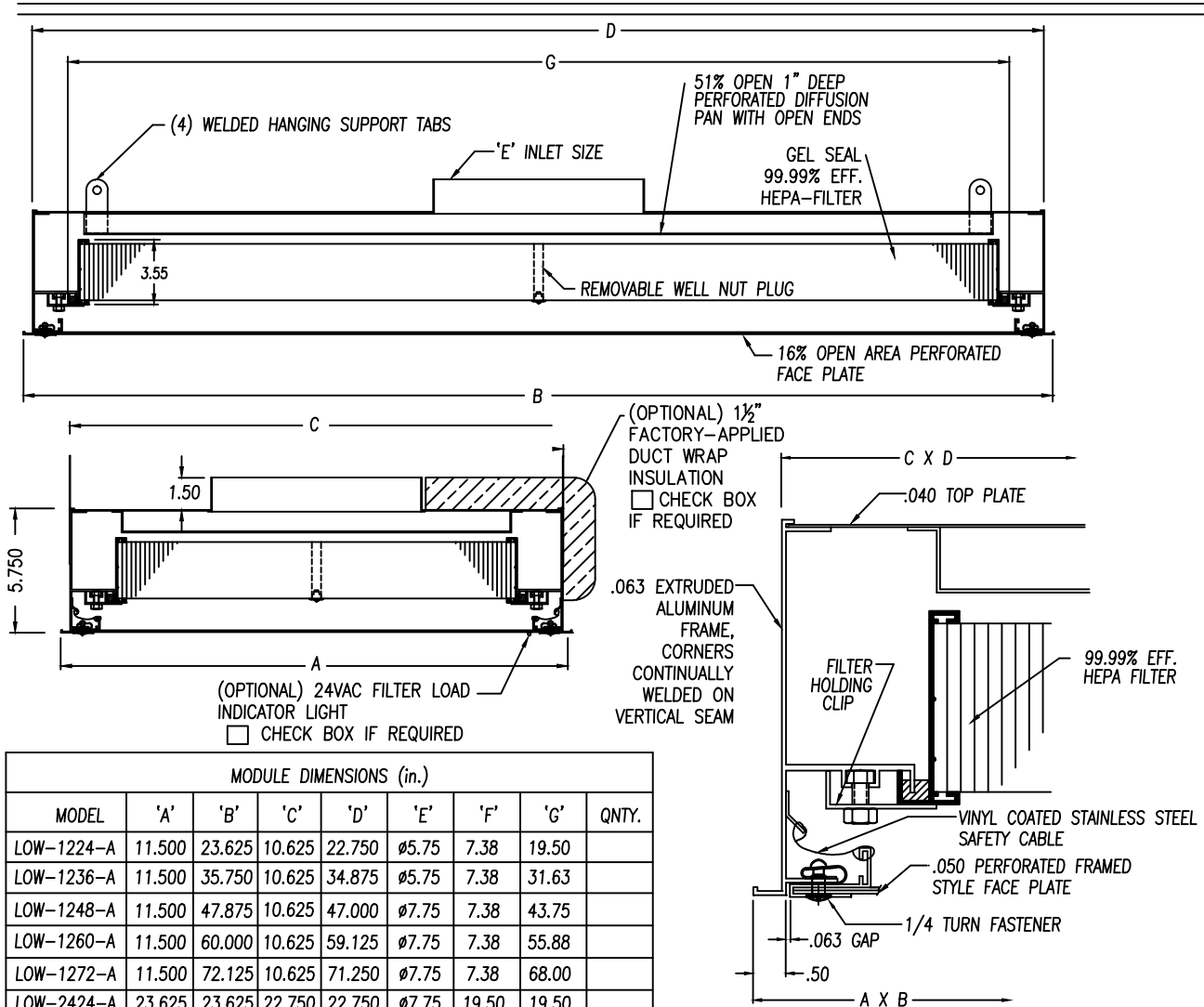

MODULE DIMENSIONS (in.)								
MODEL	'A'	'B'	'C'	'D'	'E'	'F'	'G'	QNTY.
LOW-1224-A	11.500	23.625	10.625	22.750	ø5.75	7.38	19.50	
LOW-1236-A	11.500	35.750	10.625	34.875	ø5.75	7.38	31.63	
LOW-1248-A	11.500	47.875	10.625	47.000	ø7.75	7.38	43.75	
LOW-1260-A	11.500	60.000	10.625	59.125	ø7.75	7.38	55.88	
LOW-1272-A	11.500	72.125	10.625	71.250	ø7.75	7.38	68.00	
LOW-2424-A	23.625	23.625	22.750	22.750	ø7.75	19.50	19.50	
LOW-2436-A	23.625	35.750	22.750	34.875	ø7.75	19.50	31.63	
LOW-2448-A	23.625	47.875	22.750	47.000	ø7.75	19.50	43.75	
LOW-2448-A					ø9.75			
LOW-2460-A	23.625	60.000	22.750	59.125	ø9.75	19.50	55.88	
LOW-2472-A	23.625	72.125	22.750	71.250	ø11.75	19.50	68.00	
LOW-3636-A	35.750	35.750	34.875	34.875	ø9.75	31.63	31.63	
LOW-3648-A	35.750	47.875	34.875	47.000	ø11.75	31.63	43.75	
LOW-3660-A	35.750	60.000	34.875	59.125	ø11.75	31.63	55.88	

PACKAGING NOTE: FACEPLATE & INLET COLLAR PROTECTED WITH SELF-ADHESIVE PLASTIC MATERIAL.

NOTES:

- INDICATE FACEPLATE STYLE:
 F = FRAMED * W = WRAP-AROUND
 * NOT OFFERED IN STAINLESS STEEL
- INDICATE MATERIAL / FINISH:
 0 = ALUMINUM / WHITE BAKED ENAMEL
 1 = ALUMINUM / CLEAR ANODIZED
 2 = ALUMINUM / CLEAR ANODIZED WITH 304 SST FACEPLATE / No. 4 POLISH
 4 = ALUMINUM DIFFUSER / WHITE BAKED ENAMEL WITH 304 SST FACEPLATE / No. 4 POLISH
- ALL DIMENSIONS SHOWN IN INCHES.

FORM 4-229, EFFECTIVE 10/2018

JOB: _____
 ENGINEER: _____
 ARCHITECT: _____
 CONTRACTOR: _____



PHONE: 1-800-404-0931 www.precisionairproducts.com

THE ITEMS SHOWN ON THIS DRAWING MAY BE COVERED BY ONE OR MORE PATENTS OF PRECISION AIR PRODUCTS CO. THE DESIGN AND DRAWING ARE THE PROPERTY OF THE CORPORATION AND DUPLICATION IS NOT PERMITTED, EXCEPT WITH WRITTEN CONSENT FROM THE CORPORATION. DIMENSIONS SHOWN ARE SUBJECT TO NORMAL MANUFACTURING TOLERANCES. THIS DRAWING IS FOR SUBMITTAL PURPOSES ONLY AND SUBJECT TO REVISION.

HEPA-FILTERS

FOR USE WITH HEP-DS-A, HEP-DS-B &
LOW-A UNITS

MODEL GEL-L
MODEL GEL-M
GEL SEAL FILTER

LOW FLOW - 53mm MEDIA
MEDIUM FLOW - 70mm MEDIA

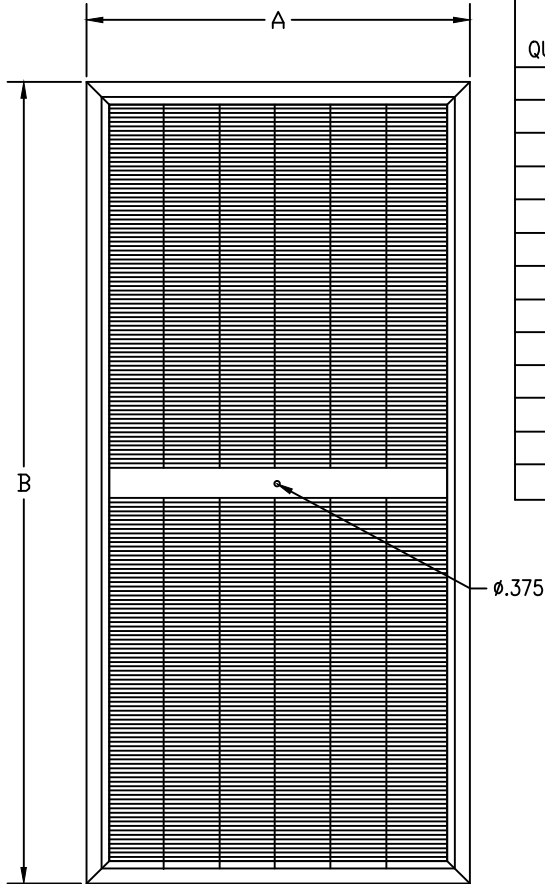

QUANTITY	NOMINAL DIFFUSER SIZE	FILTER SIZE		ACTIVE MEDIA AREA W/ CENTER BOARD	ACTIVE MEDIA AREA W/O CENTER BOARD
		A	B		
1 x 2		7.375	19.500	0.57 ft ²	0.61 ft ²
1 x 3		7.375	31.625	1.00 ft ²	1.04 ft ²
1 x 4		7.375	43.750	1.43 ft ²	**
1 x 5		7.375	55.875	1.86 ft ²	**
1 x 6		7.375	68.000	2.29 ft ²	**
2 x 2		19.500	19.500	1.91 ft ²	2.06 ft ²
2 x 3		19.500	31.625	3.36 ft ²	3.51 ft ²
2 x 4		19.500	43.750	4.81 ft ²	**
2 x 5		19.500	55.875	6.26 ft ²	**
2 x 6		19.500	68.000	7.71 ft ²	**
3 x 3		31.625	31.625	5.72 ft ²	**
3 x 4		31.625	43.750	8.19 ft ²	**
3 x 5		31.625	55.875	10.67 ft ²	**

* CENTER BOARD REQUIRED ON ALL DIFFUSERS WITH TOP INLETS. DIFFUSERS WITH SIDE OR END INLETS DO NOT REQUIRE CENTER BOARDS EXCEPT FOR SIZES AS NOTED ABOVE.

** NOT AVAILABLE WITHOUT CENTER BOARD.

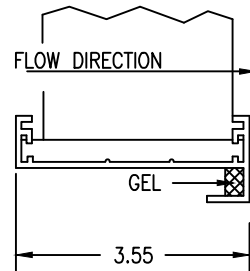

NOTES:

1. FILTER MEDIA: UNIFORM NON-SHED MICRO-GLASS
2. SEPARATOR MAT'L: HOT MELT SPACED AT 44mm INTERVALS
3. FRAME MAT'L: 6063-T5 ANODIZED ALUMINUM (CENTER DIVIDER PROVIDED ON SIZES LARGER THAN 4' LONG. OPTIONAL ON LOW-A MODEL OR HEP-DS-A/B w/ SIDE/END INLETS.)
4. SEALANT MAT'L: FIRE-RETARDANT SELF-EXTINGUISHING POLYURETHANE, LOW-OUTGASSING
5. SEAL: NON-FLOWING URETHANE GEL IN CHANNEL ON DOWNSTREAM SIDE OF FLANGE

FILTER SPECIFICATIONS:

EFFICIENCY: 99.99% @ 0.3 MICRON

✓	PLEAT DEPTH	RESISTANCE
	53mm	0.45" w.g. @ 100 FPM
	70mm	0.34" w.g. @ 100 FPM

FORM 4-235 EFF. 10/2018

JOB: _____
ENGINEER: _____
ARCHITECT: _____
CONTRACTOR: _____



PHONE: 1-800-404-0931 www.precisionairproducts.com

THE ITEMS SHOWN ON THIS DRAWING MAY BE COVERED BY ONE OR MORE PATENTS OF PRECISION AIR PRODUCTS CO. THE DESIGN AND DRAWING ARE THE PROPERTY OF THE CORPORATION AND DUPLICATION IS NOT PERMITTED, EXCEPT WITH WRITTEN CONSENT FROM THE CORPORATION. DIMENSIONS SHOWN ARE SUBJECT TO NORMAL MANUFACTURING TOLERANCES. THIS DRAWING IS FOR SUBMITTAL PURPOSES ONLY AND SUBJECT TO REVISION.

LAMI-VENT™, HEPA-VENT DS, LOW-PROFILE HEPA-VENT FACE PLATE STYLE

DETAILS

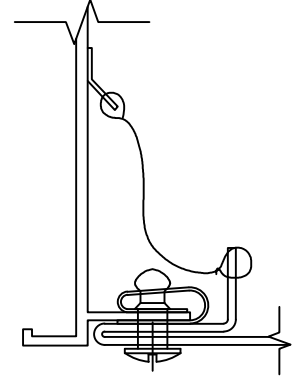
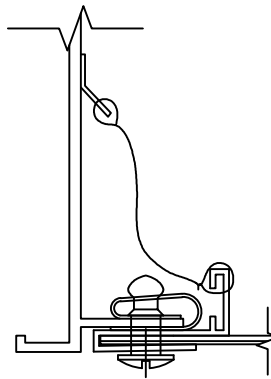
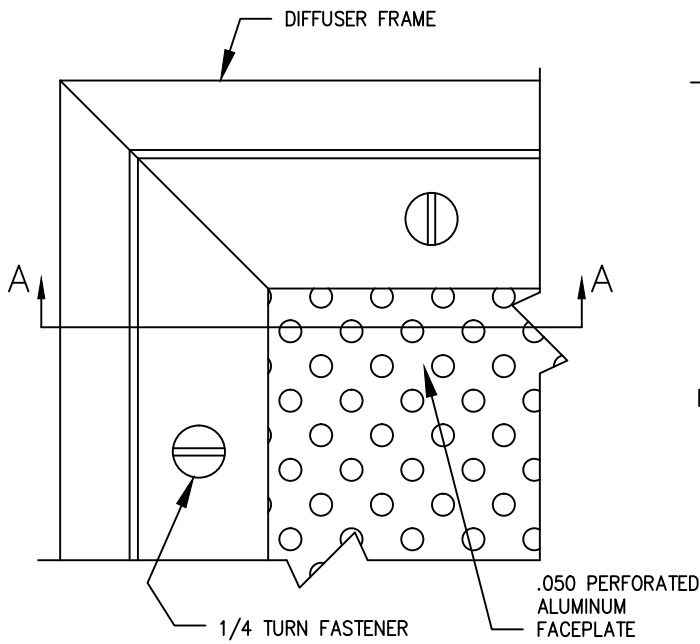

FRAMED FACEPLATE STYLE (STANDARD)

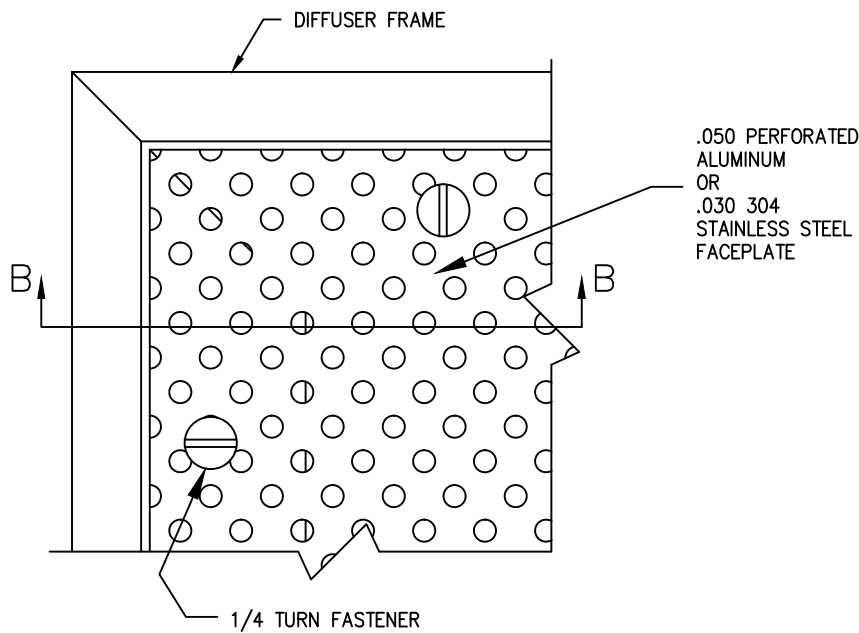

WRAP-AROUND FACEPLATE (OPTIONAL)

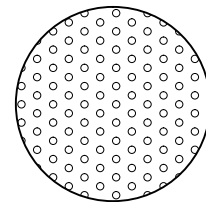

16% OPEN PERF.
FOR 'A' SERIES DIFFUSER

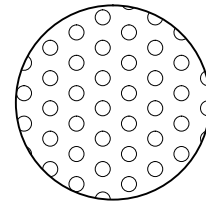

23% OPEN PERF.
FOR 'B' SERIES DIFFUSER

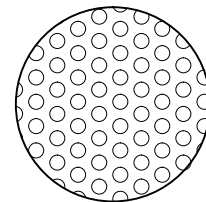

33% OPEN PERF.
FOR 'C', 'D' & 'E' SERIES DIFFUSER

FORM #4-132, EFFECTIVE 10/2018

JOB: _____
ENGINEER: _____
ARCHITECT: _____
CONTRACTOR: _____



PHONE: 1-800-404-0931 www.precisionairproducts.com

THE ITEMS SHOWN ON THIS DRAWING MAY BE COVERED BY ONE OR MORE PATENTS OF PRECISION AIR PRODUCTS CO. THE DESIGN AND DRAWING ARE THE PROPERTY OF THE CORPORATION AND DUPLICATION IS NOT PERMITTED, EXCEPT WITH WRITTEN CONSENT FROM THE CORPORATION. DIMENSIONS SHOWN ARE SUBJECT TO NORMAL MANUFACTURING TOLERANCES. THIS DRAWING IS FOR SUBMITTAL PURPOSES ONLY AND SUBJECT TO REVISION.

LOW-PROFILE HEPA-VENT

T-BAR PLASTER FRAME OPTION

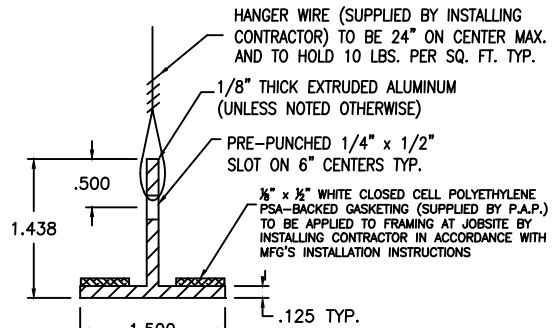
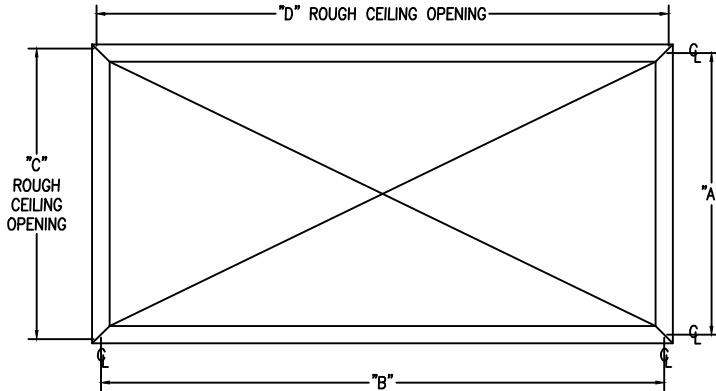

TEE DETAIL

PLASTER FRAME DIMENSIONS (in.)					
MODEL	'A'	'B'	'C'	'D'	QNTY.
PLFW-1212	12.125	12.125	12.875	12.875	
PLFW-1224	12.125	24.250	12.875	25.000	
PLFW-1236	12.125	36.375	12.875	37.125	
PLFW-1248	12.125	48.500	12.875	49.250	
PLFW-1260	12.125	60.625	12.875	61.375	
PLFW-1272	12.125	72.750	12.875	73.500	
PLFW-2424	24.250	24.250	25.000	25.000	
PLFW-2436	24.250	36.375	25.000	37.125	
PLFW-2448	24.250	48.500	25.000	49.250	
PLFW-2460	24.250	60.625	25.000	61.375	
PLFW-2472	24.250	72.750	25.000	73.500	
PLFW-3636	36.375	36.375	37.125	37.125	
PLFW-3648	36.375	48.500	37.125	49.250	
PLFW-3660	36.375	60.625	37.125	61.375	

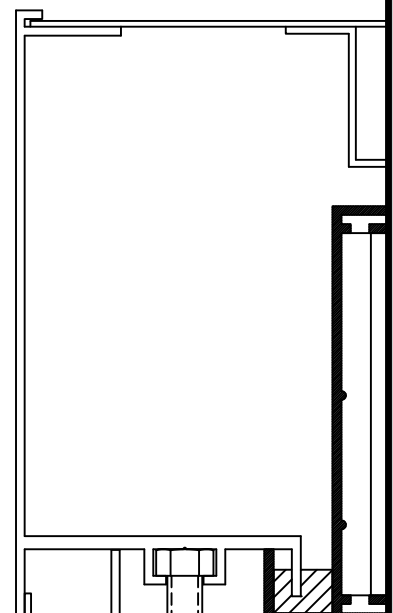

NOTES:

- INDICATE MATERIAL / FINISH:
 - 0 = ALUMINUM / WHITE BAKED ENAMEL
 - 1 = ALUMINUM / CLEAR ANODIZED
 - 2 = 16 Ga. 304 STAINLESS STEEL / No. 4 POLISH

2. ALL DIMENSIONS SHOWN IN INCHES.

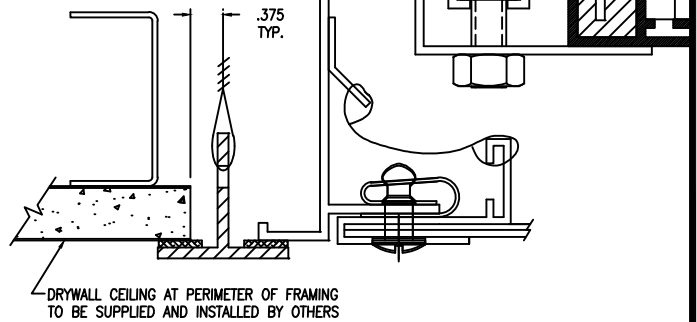

FORM 4-242, EFFECTIVE 10/2018

JOB: _____
 ENGINEER: _____
 ARCHITECT: _____
 CONTRACTOR: _____



PHONE: 1-800-404-0931 www.precisionairproducts.com

THE ITEM SHOWN ON THIS DRAWING MAY BE COVERED BY ONE OR MORE PATENTS OF PRECISION AIR PRODUCTS CO. THE DESIGN AND DRAWING ARE THE PROPERTY OF THE CORPORATION AND DUPLICATION IS NOT PERMITTED EXCEPT WITH WRITTEN CONSENT FROM THE CORPORATION. DIMENSIONS SHOWN ARE SUBJECT TO NORMAL MANUFACTURING TOLERANCES. THIS DRAWING IS FOR SUBMITTAL PURPOSES ONLY AND SUBJECT TO REVISION.