

# SURGICAIR® PLENUM INTEGRATED CEILING SYSTEM

SAMPLE REFLECTED CEILING PLAN W/ 2 SURGICAL LIGHTS & 2 BOOMS  
1-1/2" TEE

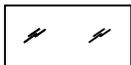

GRID/LAY-IN/RECESSED SIZE LIGHTING FIXTURE,  
SUPPLIED BY OTHERS.

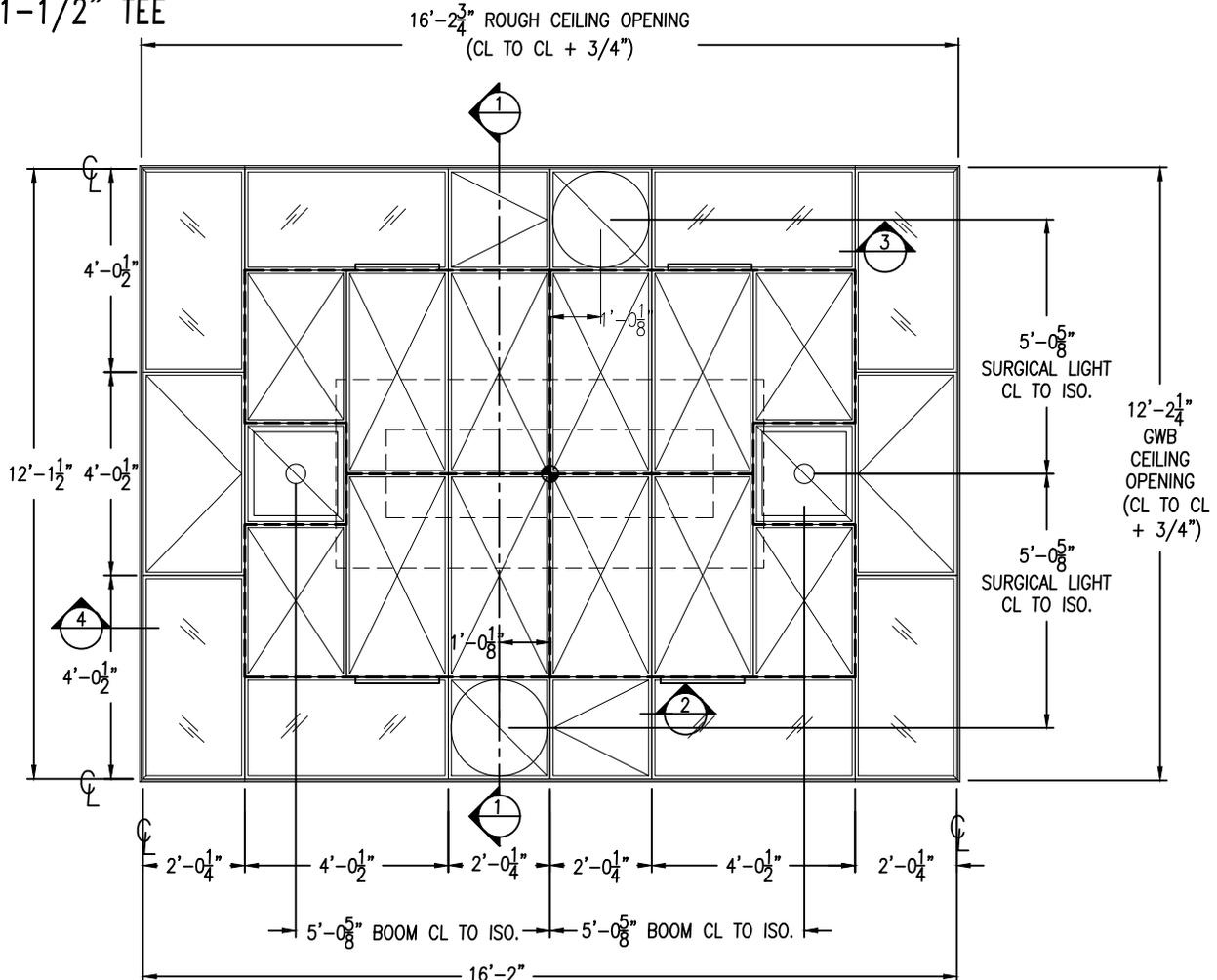

LAMI-VENT OR HEPA DIFFUSER WITHIN PLENUM  
SECTION. REFER TO MECHANICAL PLAN FOR  
PLENUM & INLET DETAILS.



BLANK-OFF/FILL-IN PANEL. ANY CUTS REQUIRED FOR  
ACCEPTANCE OF BOOM STRUCTURAL TO BE  
COMPLETED IN FIELD BY INSTALLING CONTRACTOR.  
REFER TO FILL-IN PANEL CUT SHEETS FOR DETAILS.



REMOVABLE BLANK-OFF/FILL-IN PANEL FOR BOOM  
ACCESS.

NOTES:

1. ALL DIMENSIONS TO CENTERLINE OF TEE UNLESS OTHERWISE NOTED.
2. PERIMETER FRAMING FOR LIGHTS TO BE SUPPLIED IN:  
4 - 2' x 12' SECTIONS
3. GASKETED FRAMING IS INTEGRAL TO (4) 4'x6' PLENUM SECTIONS;  
FACTORY-WELDED.
4. FINISH:  WHITE BAKED ENAMEL  
 CLEAR ANODIZED ALUMINUM

FORM 5-221, EFF. 12/2018

JOB: \_\_\_\_\_  
ENGINEER: \_\_\_\_\_  
ARCHITECT: \_\_\_\_\_  
CONTRACTOR: \_\_\_\_\_



PHONE: 1-800-404-0931 www.precisionairproducts.com

THE ITEMS SHOWN ON THIS DRAWING MAY BE COVERED BY ONE OR MORE PATENTS OF PRECISION AIR PRODUCTS CO. THE DESIGN AND DRAWING ARE THE PROPERTY OF THE CORPORATION AND DUPLICATION IS NOT PERMITTED. EXCEPT WITH WRITTEN CONSENT FROM THE CORPORATION. DIMENSIONS SHOWN ARE SUBJECT TO NORMAL MANUFACTURING TOLERANCES. THIS DRAWING IS FOR SUBMITTAL PURPOSES ONLY AND SUBJECT TO REVISION.

# SURGICAIR® PLENUM INTEGRATED CEILING SYSTEM

## SECTION THROUGH CEILING (SAMPLE WITH LAMI-VENT™ DIFFUSERS)

CHOICE OF DIFFUSER TYPE WITHIN PLENUM (LAMI-VENTS SHOWN.  
FOR HEPA FILTERED PLENUM REFER TO DWG. #5-223. REFER TO  
DIFFUSER SUBMITTALS FOR ADDITIONAL PRODUCT DETAILS.  
NOTES 1 & 4.

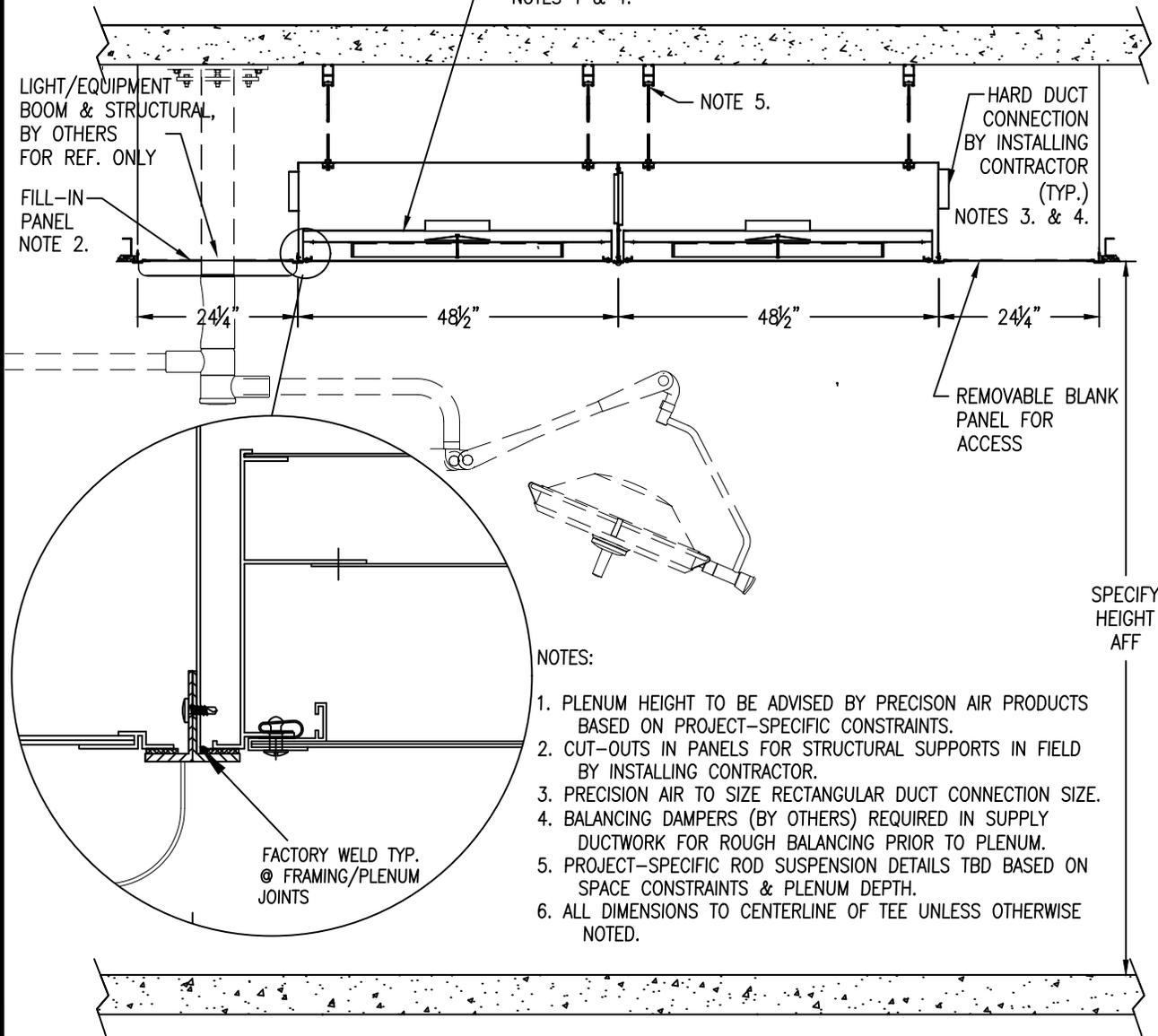

NOTES:

1. PLENUM HEIGHT TO BE ADVISED BY PRECISION AIR PRODUCTS BASED ON PROJECT-SPECIFIC CONSTRAINTS.
2. CUT-OUTS IN PANELS FOR STRUCTURAL SUPPORTS IN FIELD BY INSTALLING CONTRACTOR.
3. PRECISION AIR TO SIZE RECTANGULAR DUCT CONNECTION SIZE.
4. BALANCING DAMPERS (BY OTHERS) REQUIRED IN SUPPLY DUCTWORK FOR ROUGH BALANCING PRIOR TO PLENUM.
5. PROJECT-SPECIFIC ROD SUSPENSION DETAILS TBD BASED ON SPACE CONSTRAINTS & PLENUM DEPTH.
6. ALL DIMENSIONS TO CENTERLINE OF TEE UNLESS OTHERWISE NOTED.

1 SECTION THROUGH CEILING

FORM 5-222, EFF. 12/2018

JOB: \_\_\_\_\_  
 ENGINEER: \_\_\_\_\_  
 ARCHITECT: \_\_\_\_\_  
 CONTRACTOR: \_\_\_\_\_



PHONE: 1-800-404-0931 www.precisionairproducts.com

THE ITEMS SHOWN ON THIS DRAWING MAY BE COVERED BY ONE OR MORE PATENTS OF PRECISION AIR PRODUCTS CO. THE DESIGN AND DRAWING ARE THE PROPERTY OF THE CORPORATION AND DUPLICATION IS NOT PERMITTED, EXCEPT WITH WRITTEN CONSENT FROM THE CORPORATION. DIMENSIONS SHOWN ARE SUBJECT TO NORMAL MANUFACTURING TOLERANCES. THIS DRAWING IS FOR SUBMITTAL PURPOSES ONLY AND SUBJECT TO REVISION.

# SURGICAIR® PLENUM INTEGRATED CEILING SYSTEM

## 1-1/2" WIDE PROFILE SECTIONS

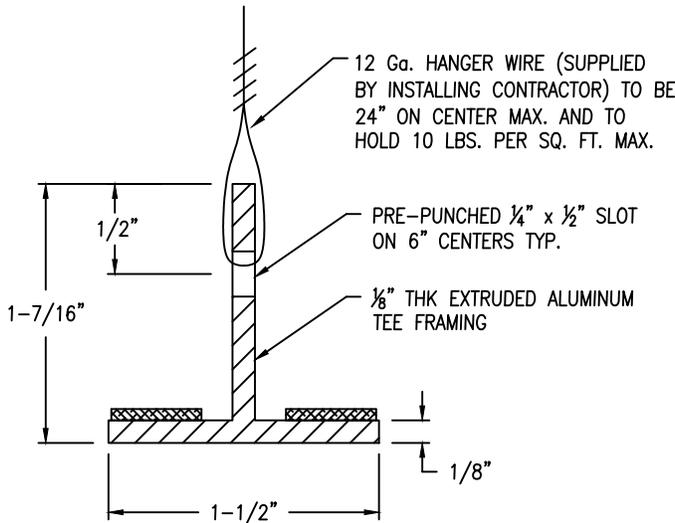

2 TYP. SECTION THRU TEE WIRE HANGER OPTION

WHITE CLOSED-CELL POLYETHYLENE GASKET TAPE 0.75" WD x 0.031" THK. - FURN BY PAP, APPLIED BY CONTR.

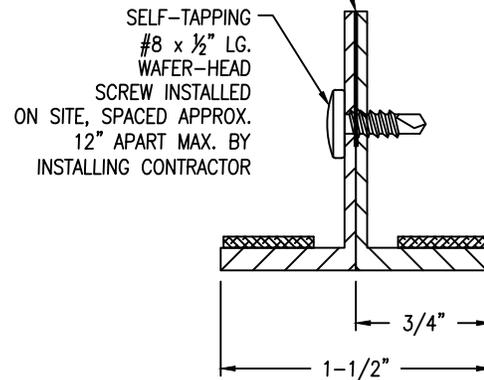

3 SECTION AT BUTTING L's

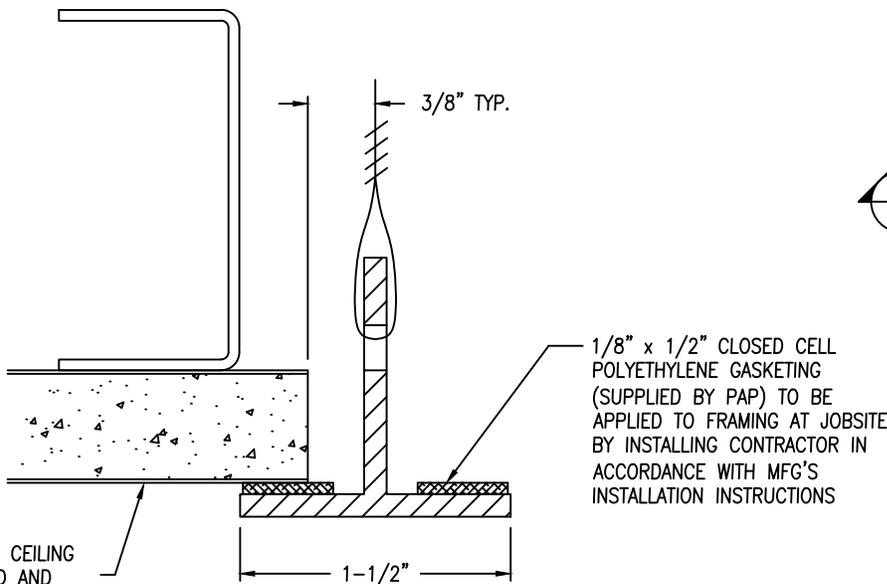

4 SECTION AT FRAMING PERIMETER

FORM 5-224, EFF. 12/2018

JOB: \_\_\_\_\_  
 ENGINEER: \_\_\_\_\_  
 ARCHITECT: \_\_\_\_\_  
 CONTRACTOR: \_\_\_\_\_



PHONE: 1-800-404-0931 www.precisionairproducts.com

THE ITEMS SHOWN ON THIS DRAWING MAY BE COVERED BY ONE OR MORE PATENTS OF PRECISION AIR PRODUCTS CO. THE DESIGN AND DRAWING ARE THE PROPERTY OF THE CORPORATION AND DUPLICATION IS NOT PERMITTED, EXCEPT WITH WRITTEN CONSENT FROM THE CORPORATION. DIMENSIONS SHOWN ARE SUBJECT TO NORMAL MANUFACTURING TOLERANCES. THIS DRAWING IS FOR SUBMITTAL PURPOSES ONLY AND SUBJECT TO REVISION.

# LAMI-VENT™

MODEL: PAT-A (20-40 CFM/FT<sup>2</sup>)

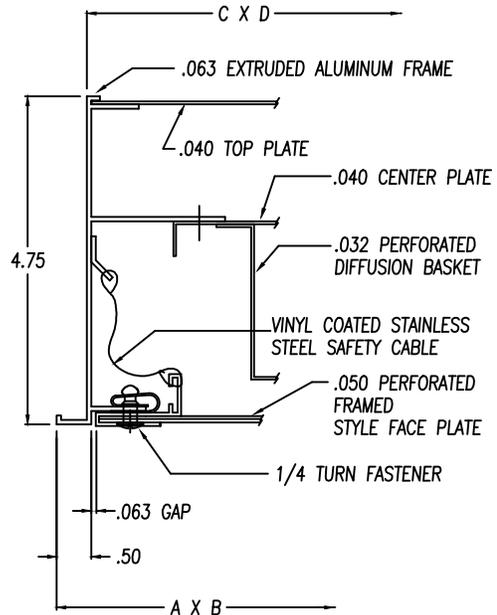
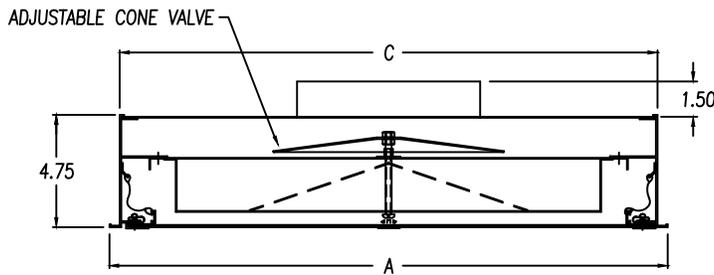
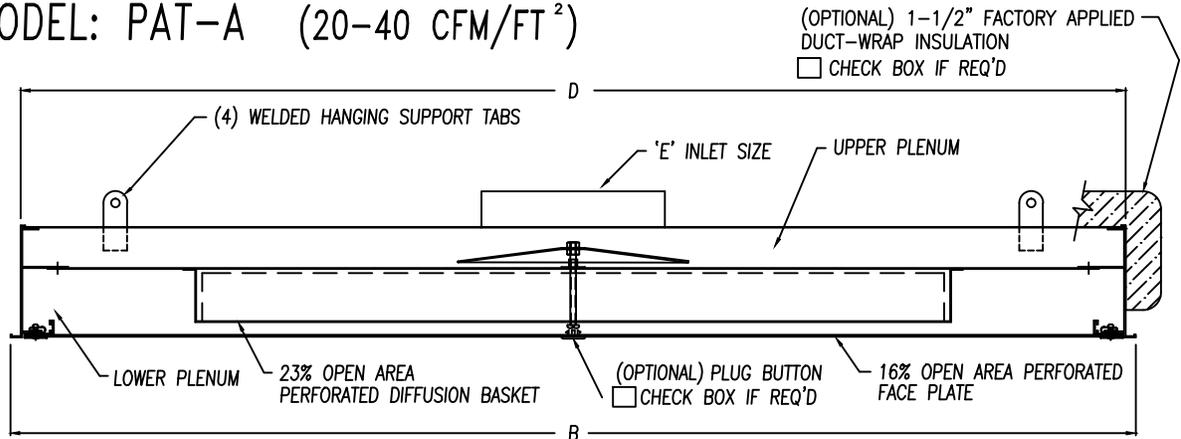

MODULE DIMENSIONS (in.)						
MODEL	'A'	'B'	'C'	'D'	'E'	QNTY.
PAT-1212-A	11.500	11.500	10.625	10.625	ø5.75	
PAT-1224-A	11.500	23.625	10.625	22.750	ø5.75	
PAT-1236-A	11.500	35.750	10.625	34.875	ø5.75	
PAT-1248-A	11.500	47.875	10.625	47.000	ø5.75	
PAT-1260-A	11.500	60.000	10.625	59.125	ø7.75	
PAT-1272-A	11.500	72.125	10.625	71.250	ø7.75	
PAT-2424-A	23.625	23.625	22.750	22.750	ø7.75	
					ø9.75	
PAT-2436-A	23.625	35.750	22.750	34.875	ø7.75	
					ø9.75	
PAT-2448-A	23.625	47.875	22.750	47.000	ø7.75	
					ø9.75	
					ø11.75	
PAT-2460-A	23.625	60.000	22.750	59.125	ø9.75	
PAT-2472-A	23.625	72.125	22.750	71.250	ø9.75	
PAT-3636-A	35.750	35.750	34.875	34.875	ø9.75	
PAT-3648-A	35.750	47.875	34.875	47.000	ø9.75	
PAT-3660-A	35.750	60.000	34.875	59.125	ø11.75	

**NOTES:**

- INDICATE FACEPLATE STYLE:  
 F = FRAMED \*     W = WRAP-AROUND  
 \* NOT OFFERED IN STAINLESS STEEL
- INDICATE MATERIAL / FINISH:  
 0 = ALUMINUM / WHITE BAKED ENAMEL  
 1 = ALUMINUM / CLEAR ANODIZED  
 2 = ALUMINUM / CLEAR ANODIZED WITH 304 SST FACEPLATE / No. 4 POLISH  
 3 = 304 STAINLESS STEEL / No. 4 POLISH ON ROOM-SIDE SURFACES  
 4 = ALUMINUM DIFFUSER / WHITE BAKED ENAMEL WITH 304 SST FACEPLATE / No. 4 POLISH
- ALL DIMENSIONS SHOWN IN INCHES.

FORM 4-120, EFFECTIVE 10/2018

JOB: \_\_\_\_\_  
 ENGINEER: \_\_\_\_\_  
 ARCHITECT: \_\_\_\_\_  
 CONTRACTOR: \_\_\_\_\_



PHONE: 1-800-404-0931    www.precisionairproducts.com

THE ITEMS SHOWN ON THIS DRAWING MAY BE COVERED BY ONE OR MORE PATENTS OF PRECISION AIR PRODUCTS CO. THE DESIGN AND DRAWING ARE THE PROPERTY OF THE CORPORATION AND DUPLICATION IS NOT PERMITTED, EXCEPT WITH WRITTEN CONSENT FROM THE CORPORATION. DIMENSIONS SHOWN ARE SUBJECT TO NORMAL MANUFACTURING TOLERANCES. THIS DRAWING IS FOR SUBMITTAL PURPOSES ONLY AND SUBJECT TO REVISION.

# FILL- IN PANELS WITH SOLID FACE

MODEL SFP

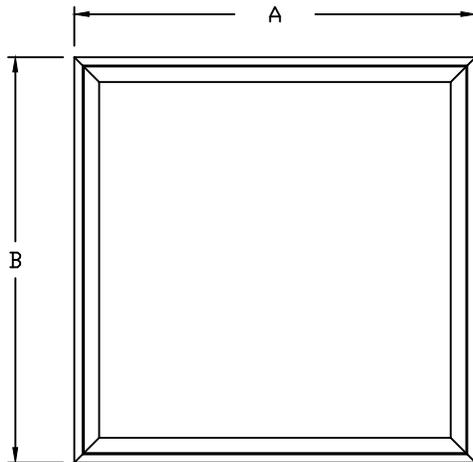

FRAMED STYLE

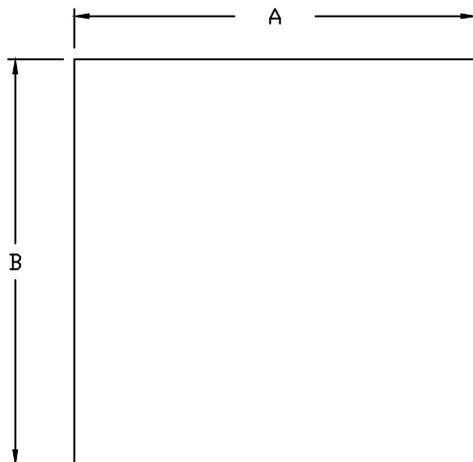
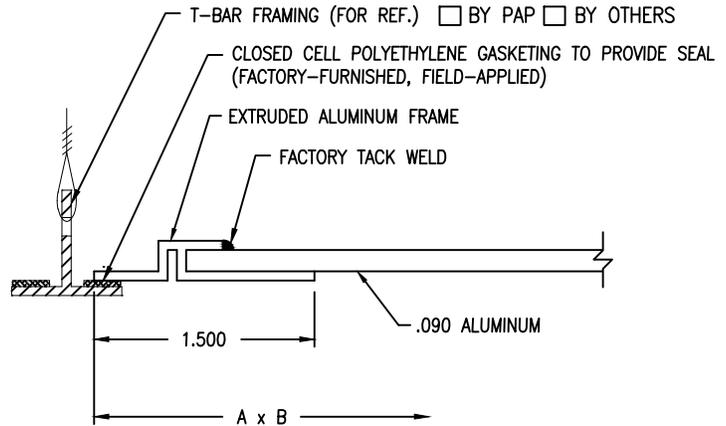

WRAP-AROUND STYLE

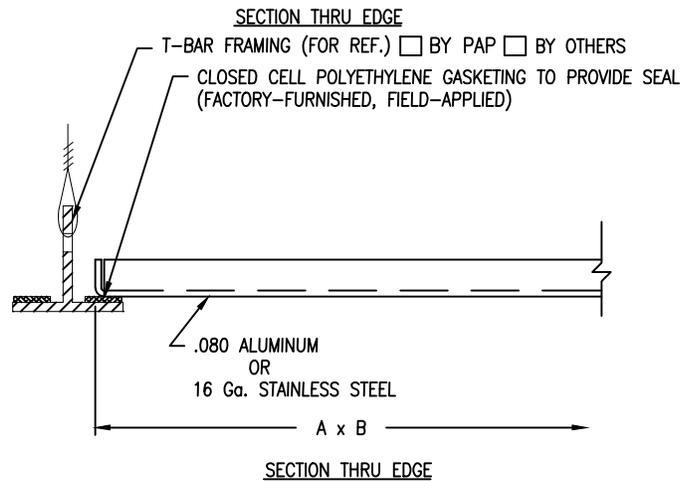

MODEL	'A'	'B'	QNTY	MODEL	'A'	'B'	QNTY	MODEL	'A'	'B'	QNTY
SFP-1212	11.500	11.500		SFP-2424	23.625	23.625		SFP-3636	35.750	35.750	
SFP-1224	11.500	23.625		SFP-2436	23.625	35.750		SFP-3648	35.750	47.875	
SFP-1236	11.500	35.750		SFP-2448	23.625	47.875		SFP-3660	35.750	60.000	
SFP-1248	11.500	47.875		SFP-2460	23.625	60.000		SFP-3672	35.750	72.125	
SFP-1260	11.500	60.000		SFP-2472	23.625	72.125		SFP-4848	47.875	47.875	
SFP-1272	11.500	72.125									

**NOTES:**

- INDICATE MATERIAL  
 ALL ALUM.  
 ALL 304 S.S.
- INDICATE FINISH TO MATCH DIFFUSERS:  
 WHITE BAKED ENAMEL  CLEAR ANODIZED ALUM.  
 #4 POLISHED S.S.
- INDICATE FACEPLATE STYLE:  
 FRAMED\*  WRAP-AROUND  
 \* NOT OFFERED IN STAINLESS STEEL

FORM 5-130, EFF. 10/2018

JOB: \_\_\_\_\_  
 ENGINEER: \_\_\_\_\_  
 ARCHITECT: \_\_\_\_\_  
 CONTRACTOR: \_\_\_\_\_



PHONE: 1-800-404-0931 www.precisionairproducts.com

THE ITEMS SHOWN ON THIS DRAWING MAY BE COVERED BY ONE OR MORE PATENTS OF PRECISION AIR PRODUCTS CO. THE DESIGN AND DRAWING ARE THE PROPERTY OF THE CORPORATION AND DUPLICATION IS NOT PERMITTED, EXCEPT WITH WRITTEN CONSENT FROM THE CORPORATION. DIMENSIONS SHOWN ARE SUBJECT TO NORMAL MANUFACTURING TOLERANCES. THIS DRAWING IS FOR SUBMITTAL PURPOSES ONLY AND SUBJECT TO REVISION.